

PGP-RC-10

PGP Polymer Cable Management System

Bulletin 7867270 Revision A Page 1 of 1

PGP-RC-10

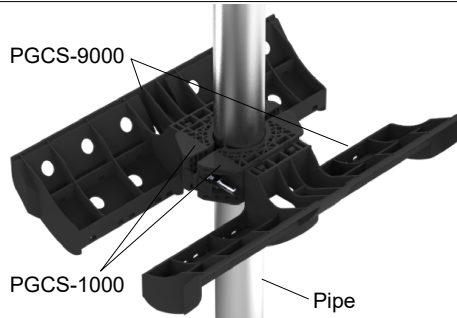

PGP-RC-10 is made from two PGCS-9000 and two PGCS-1000 plus the necessary hardware kit. Can assemble on 2-3/8" or 2-7/8" pipe with an applied torque of 15 Nm.

Installation on the pipe

First install the PGCS-9000 on the both sides of the clamp (PGCS-1000), then use hardware kit to install these two assembled clamps onto a 2-3/8" or 2-7/8" pipe.

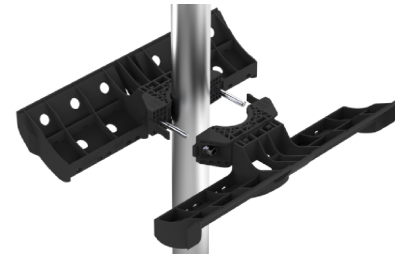

When used in conjunction with an antenna, position the assembly at the recommended distance below the antenna ports to insure correct bending requirements for the Coax Cable in use.

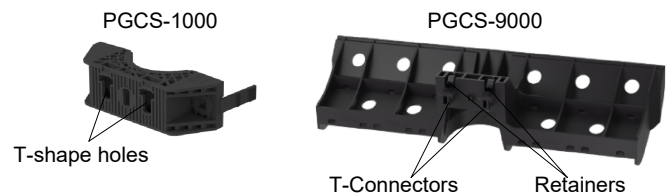
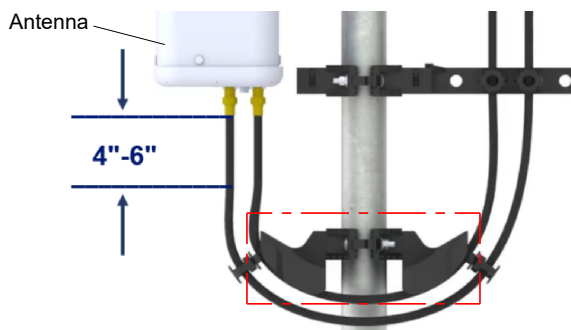

NOTE:

1. Please use the recommended torque to install the clamp.
2. Intended for Jumper Cable use only.
3. Two Snap Tak hangers per 3/4" hole position.

Assembly of wedges: Fully insert the T-Connectors into the T-shape holes, slide the T-Connectors down, until you hear a "click" to indicate that the installation is complete.

Disassembly of wedges:

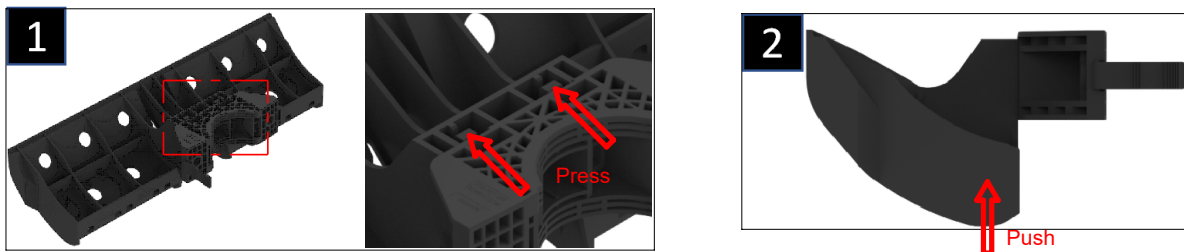

1. Press the arrow position with fingers to push back the retainers, until these retainers are back against the mounting surface, to allow the T-Connectors to release.
2. Hold the PGCS-1000, push out the PGCS-9000 as shown in the figure, and then pull it out to complete the disassembly.