

WT-HRM2-72



Water Tower Top Rail Mount, 2-3/8 in x 72 in plain end pipe included

Product Classification

Product Type Water tower mount

General Specifications

Mounting Handrail | Toe board

Pipe, quantity 1

Dimensions

Height 1,828.8 mm | 72 in

Width 203.2 mm | 8 in

Length 609.6 mm | 24 in

Pipe Length 1,828.8 mm | 72 in

Pipe Outer Diameter 60.96 mm | 2.4 in

Stand-off Distance 228.6 mm | 9 in

WT-HRM2-72

Outline Drawing

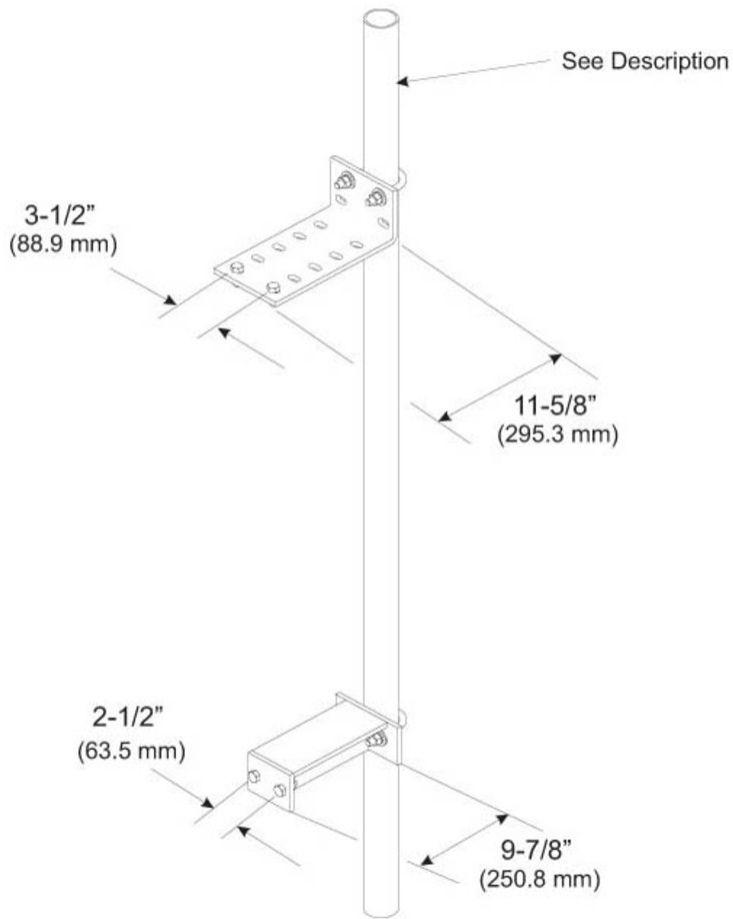

Material Specifications

Material Type Hot dip galvanized steel

Packaging and Weights

Included Hardware | Mount | Plain end pipes

Packaging quantity 1

Weight, net 19.096 kg | 42.1 lb

Regulatory Compliance/Certifications

Agency **Classification**

WT-HRM2-72

ISO 9001:2015

Designed, manufactured and/or distributed under this quality management system

Included Products

- MT-651 – Plain End Pipe, 2-3/8 in OD x 72 in .120" A500C 46Ksi
- WT-HRM2-B – Water Tower Top Rail Mount for 2-3/8 in OD mounting pipe, plain end pipe not included

MT-651

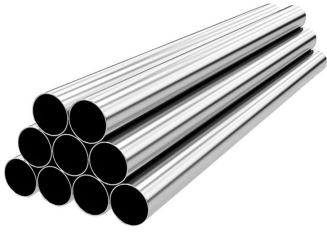

Plain End Pipe, 2-3/8 in OD x 72 in .120" A500C 46Ksi

Product Classification

Product Type Plain end pipe

General Specifications

Pipe, quantity 1

Dimensions

Height 60.96 mm | 2.4 in
Width 60.96 mm | 2.4 in
Length 1,828.8 mm | 72 in
Pipe Length 1,828.8 mm | 72 in
Pipe Outer Diameter 60.96 mm | 2.4 in
Material Thickness 3.048 mm | 0.12 in

Material Specifications

Material Type A500 | Hot dip galvanized steel
Material Grade C
Material Strength 46 KSI

Packaging and Weights

Included Pipe
Packaging quantity 1
Weight, net 8 kg | 17.637 lb

Regulatory Compliance/Certifications

Agency	Classification
CHINA-ROHS	Above maximum concentration value
ISO 9001:2015	Designed, manufactured and/or distributed under this quality management system

MT-651

ROHS	Compliant/Exempted
UK-ROHS	Compliant/Exempted



WT-HRM2-B



Water Tower Top Rail Mount for 2-3/8 in OD mounting pipe, plain end pipe not included



Product Classification

Product Type Water tower mount

General Specifications

Mounting Handrail | Toe board

Pipe, quantity 0

Dimensions

Height 889 mm | 35 in

Width 203.2 mm | 8 in

Length 609.6 mm | 24 in

Pipe Outer Diameter 60.96 mm | 2.4 in

Stand-off Distance 228.6 mm | 9 in

WT-HRM2-B

Outline Drawing

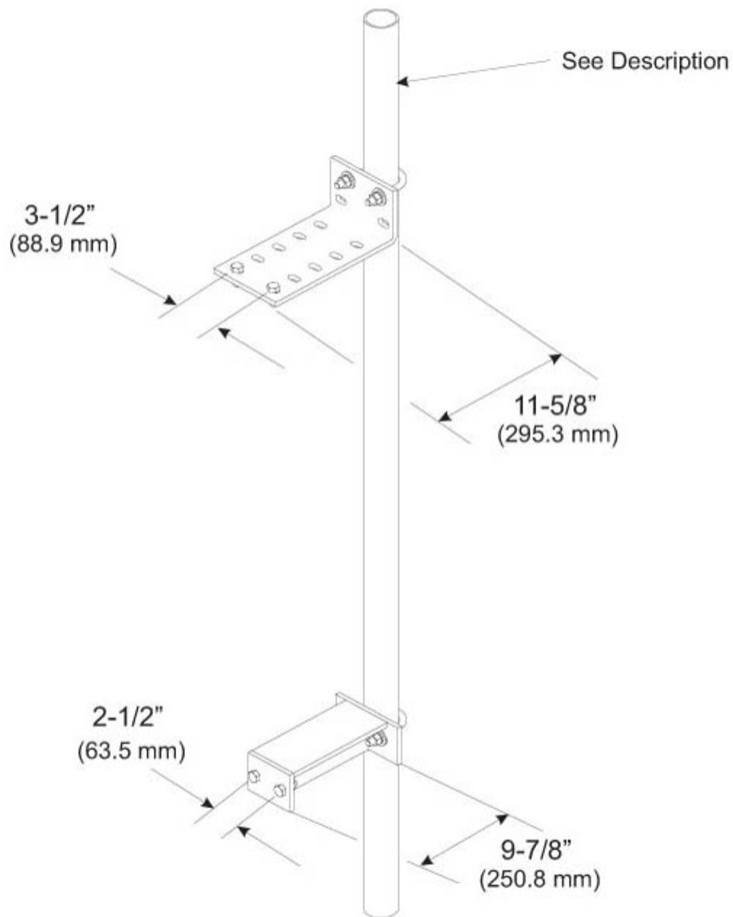

Material Specifications

Material Type Hot dip galvanized steel

Packaging and Weights

Included Hardware | Mount

Packaging quantity 1

Weight, net 9.299 kg | 20.5 lb

Regulatory Compliance/Certifications

Agency **Classification**

WT-HRM2-B

CHINA-ROHS	Below maximum concentration value
ISO 9001:2015	Designed, manufactured and/or distributed under this quality management system
REACH-SVHC	Compliant as per SVHC revision on www.andrew.com/ProductCompliance
ROHS	Compliant
UK-ROHS	Compliant

