

- 1.0 GENERAL NOTES  
 1.1 ALL METRIC DIMENSIONS ARE IN BRACKETS [X. X]  
 1.2 FOR PATENT INFO: <https://www.cs-pat.com>

- 2.0 DESIGN NOTES  
 2.1 ANY HAZARDS OR OBSTRUCTIONS TO THE CLIMBING FACILITY AND SAFETY CLIMB MUST BE IDENTIFIED PRIOR TO INSTALLING THE APPURTENANCE. ADDITIONAL PRODUCTS MAY BE REQUIRED TO MAINTAIN THE INTEGRITY OF THE SAFETY CLIMB. DURING INSTALLATION, TEMPORARY AND/OR PERMANENT PRECAUTIONARY MEASURES SHOULD BE TAKEN TO PRESERVE THE CLIMBING FACILITY AND/OR SAFETY CLIMB.

- 3.0 MANUFACTURING/SPECIAL REQUIREMENTS  
 3.1 TIGHTEN ALL BOLTS SECURING FLAT PLATES BY THE TURN-OF-NUT METHOD. TIGHTEN ALL U-BOLTS USING TURN-OF-NUT METHOD WITH ATTENTION TO LEAVE EQUAL DISTANCE AND EQUAL FORCE ON EACH LEG OF THE U-BOLT.

- 4.0 TEST  
 5.0 PACKAGING  
 5.1 PACKAGING SHALL MEET COMMSCOPE REQUIREMENTS PER DOCUMENT IS-PL-3005  
 5.2 PRINTED DOCUMENT TO BE PLACED INSIDE POLYBAG AND THEN IN SHIPPING CONTAINER  
 5.3 EXTRA HARDWARE MAY BE SUPPLIED, BAGGED AND SHIPPED

REVISIONS			
REV.	DESCRIPTION	DATE	APPROVED
A	INITIAL RELEASE	LL1090 16NOV23	EB1063 40183094CMO
B	MTC4165-LAB01 (ITEM 10) WAS MTC4165-LAB02	RY1002 12MAR24	EB1063 40190737CMO
C	GB-04165 WAS GB-03145; GWF-04 WAS GWF-03	RY1002 11APR24	EB1063 40193135CMO

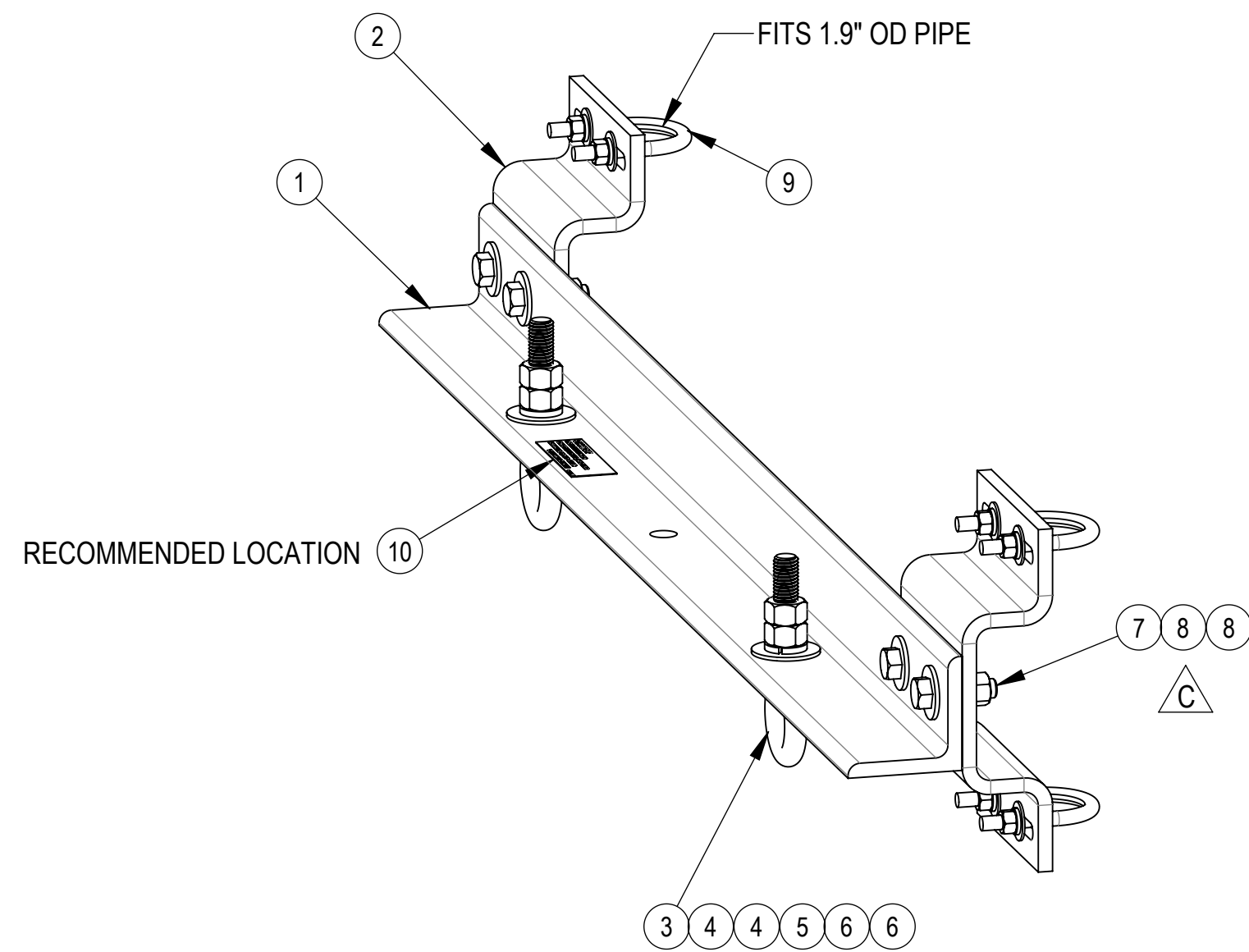
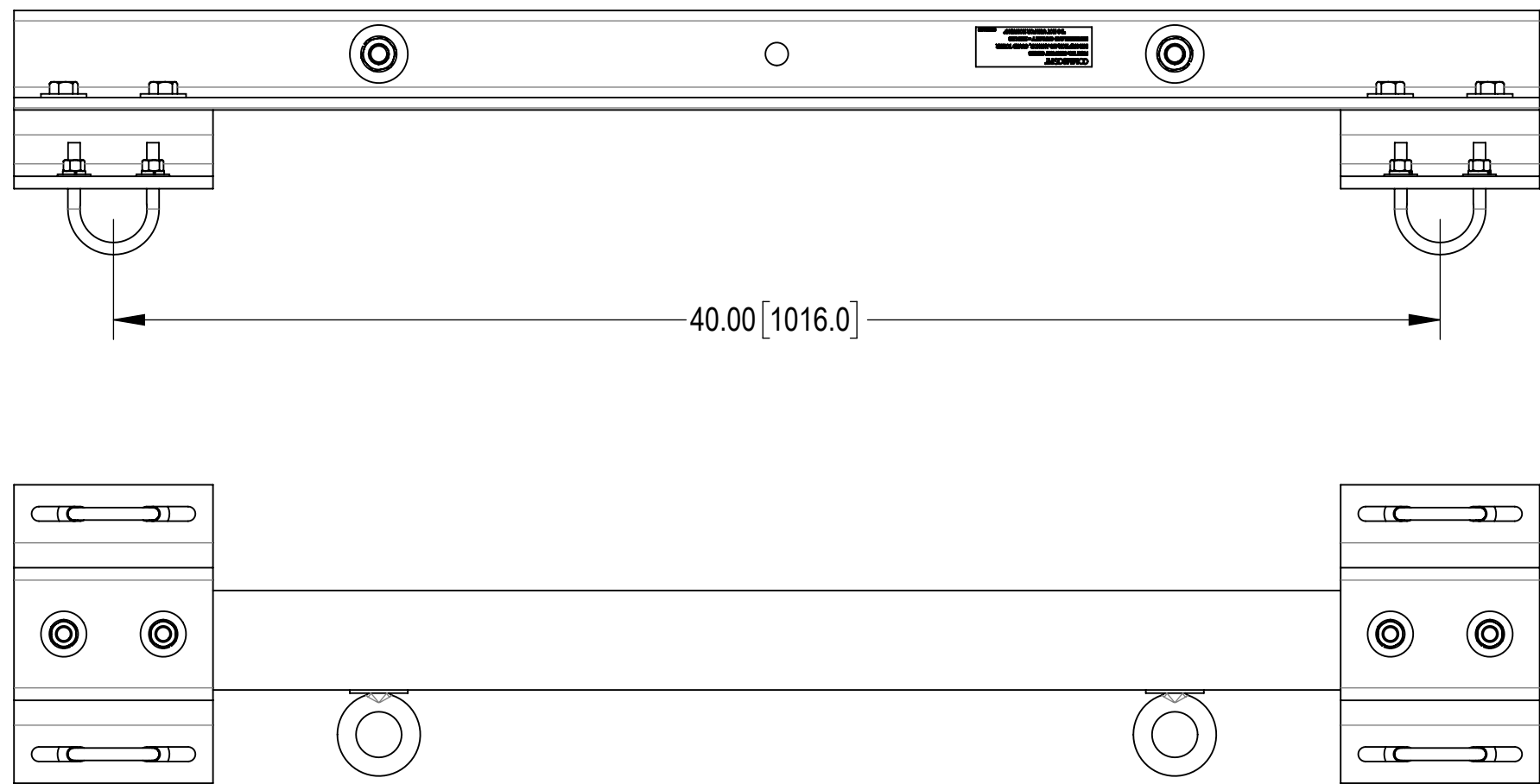

NOTE: -MAXIMUM LOAD PER EYEBOLT = 1000 LBS  
 -MAXIMUM LOAD PER GRIP ANCHOR = 2000 LBS  
 -NOT TO BE USED FOR HOISTING  
 -COMPETENT PERSON TO MAKE DETERMINATION OF USAGE ON THE STRUCTURE

COMPONENT PART NUMBERS PROVIDED FOR ASSEMBLY PURPOSES;  
 INDIVIDUAL COMPONENTS MAY BE SHIPPED AS PARTS WITHIN AN INCLUDED KIT.

ITEM NO.	PART NUMBER	DESCRIPTION	QTY.	WEIGHT	NOTE NO.
1	MTC4165-041-42-00	41-42 INCH CROSSMEMBER GALVANIZED	1	27.02 LBS	
2	MTC4166-00	STEEL OFFSET BRACKET, GALV	2	7.28 LBS	
3	9674-1	BOLT, EYE, 5/8X3, STL, ZN PLD	2	0.08 LBS	
4	GWF-05	5/8" GALV FLAT WASHER, 1.70D	4	0.06 LBS	
5	GWL-05	5/8" GALV LOCK WASHER	2	0.03 LBS	
6	GN-05	5/8" GALV HEX NUT	4	0.08 LBS	
7	GB-04165	1/2" X 1-3/4" GALV BOLT KIT	4	0.14 LBS	
8	GWF-04	1/2" GALV FLAT WASHER	8	0.04 LBS	
9	GUB3230	3/8" X 2" X 3" GALV U-BOLT	4	0.24 LBS	
10	MTC4165-LAB01	LABEL, HG ANCHOR, GUYED-TOWER	1	0.00 LBS	

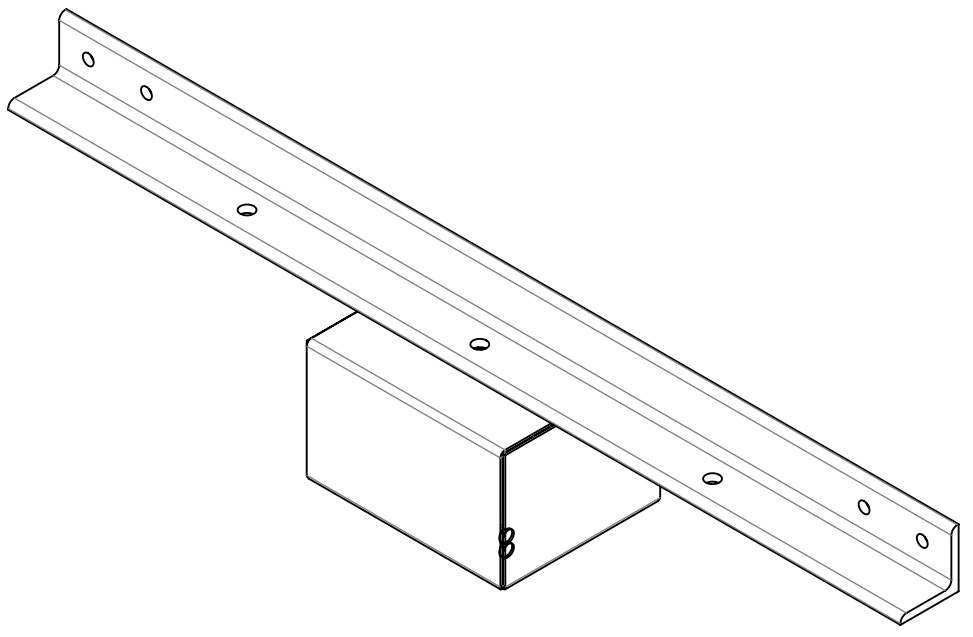

PACKAGE

DENSITY	44.70	lbs/in <sup>3</sup>
MASS	44.70	lbs
VOLUME	162.03	in <sup>3</sup>
SURFACE AREA	1067.84	in <sup>2</sup>
HEIGHT	7.36"	
LENGTH	9.00"	
WIDTH	46.00"	

© 2024 CommScope, Inc. Confidential

<b>COMMSCOPE, INC. OF NORTH CAROLINA</b>									
TOLERANCES					SAP MATERIAL MASTER				
1 PLACE .X[X] ± 0.2[6.3]			3 PLACE .XXX[X] ± 0.060[1.5]		860674607-041-42				
2 PLACE .XX[X] ± 0.12[3.0]			ANGLES ± 2°						
FINISH					MATERIAL				
UNLESS OTHERWISE SPECIFIED DIMENSIONS ARE IN INCHES INTERPRET PER ANSI Y 14.5M-1994	CE	LL1090	16NOV23	<b>HG ANCHOR, GUYED-TOWER, 41-42" FACE</b>					
	RW	RY1002	04/12/2024						
	AD	YZ1080	04/17/2024						
	RE	RY1002	04/24/2024						
	ECN	40193135CMO							
SCALE		DOCUMENT NO.			<b>860674607-041-42</b>				
1:8									
SIZE	Auth Group	INSL	MODEL			DRAWING			
C			VERSION	STATUS	REVISION	VERSION	STATUS	REVISION	SHEET
			02	RE	C	02	RE	C	1 OF 2

4

3

2

1

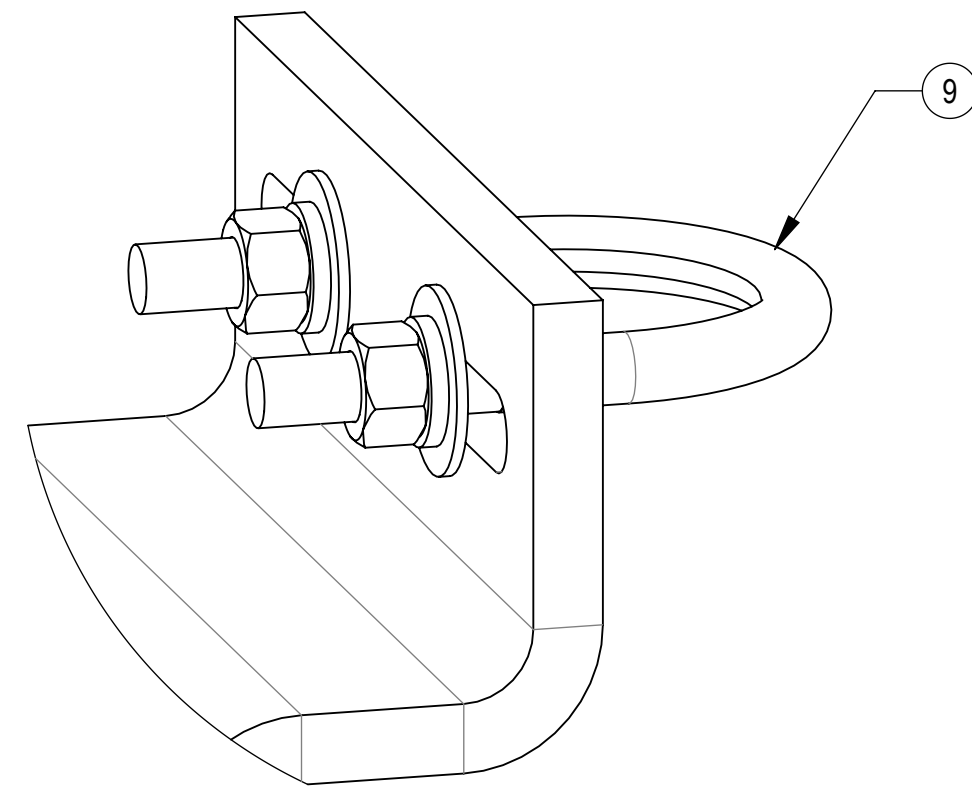

**DETAIL A**  
SCALE 1 : 1

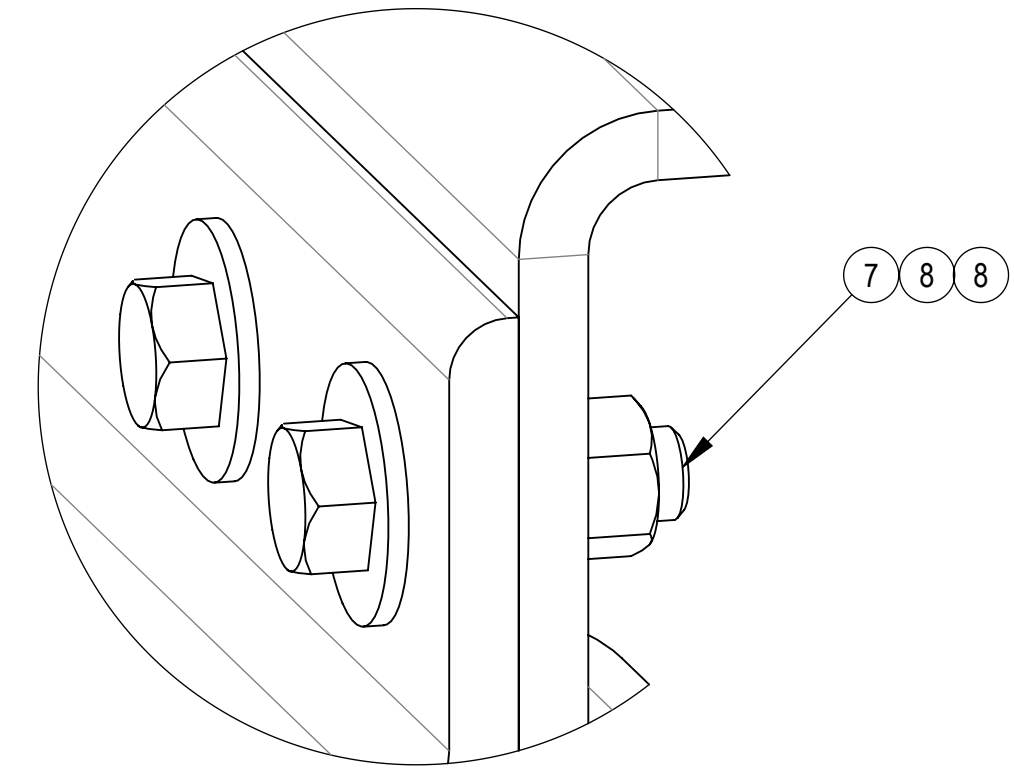

**DETAIL B**  
SCALE 1 : 1

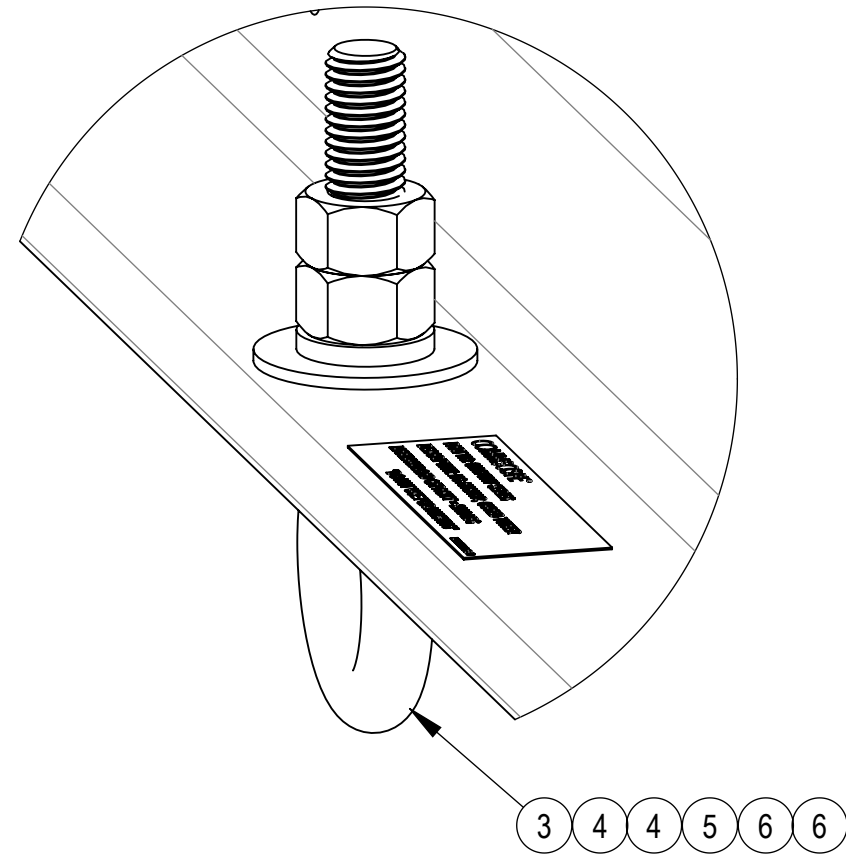

**DETAIL C**  
SCALE 2 : 3

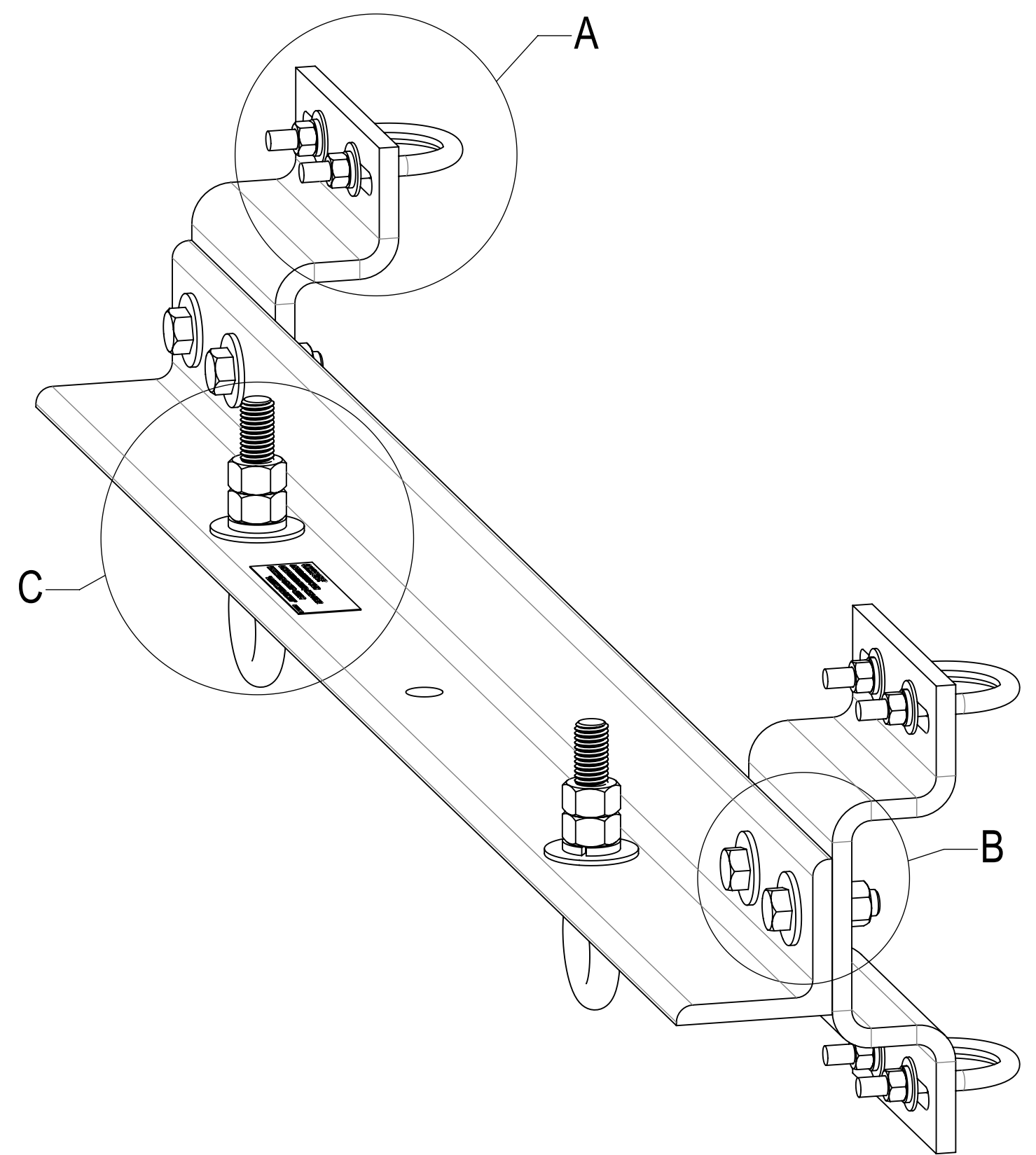

NOTE: -MAXIMUM LOAD PER EYEBOLT = 1000 LBS  
 -MAXIMUM LOAD PER GRIP ANCHOR = 2000 LBS  
 -NOT TO BE USED FOR HOISTING  
 -COMPETENT PERSON TO MAKE DETERMINATION OF USAGE  
 ON THE STRUCTURE

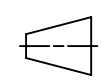
COMMSCOPE, INC. OF NORTH CAROLINA					
TITLE HG ANCHOR, GUYED-TOWER, 41-42" FACE					
SIZE <b>C</b>	SCALE <b>1:5</b>	DOCUMENT NO. 860674607-041-42			
 		DRAWING			SHEET 2 OF 2
		VERSION 02	STATUS RE	REVISION C	

4

3

2

1